



Patrick
... the particle counter

Operating Manual

Contact For technical information, please contact our customer service:

Address	HYDROTECHNIK GmbH Holzheimer Str. 94 D-65549 Limburg an der Lahn
Telephone	+49 6431 4004 0
Fax	+49 6431 45308
email	info@hydrotechnik.com
Internet	www.hydrotechnik.com

Further information To learn more about the products and services from HYDROTECHNIK GmbH, please visit our Internet site www.hydrotechnik.com or contact your local distributor.

Your experiences and feedback We appreciate your suggestions and feedback. It helps us to continually improve our products.

Safety

Display of safety instructions	4
Safety instructions.....	4
General safety instructions	5
Dangerous electrical voltage.....	6
Laser.....	6
Property damage	7
Pressure equalization membrane	8
Warning stickers on the instrument.....	9

Introduction

Scope.....	10
Copyright.....	10
Limitation of liability.....	11
Intended use	12
Warranty	12
Customer obligations	13
Authorized personnel	13
Disposal	13

Description of the Instrument

Properties.....	14
Components of the Instrument.....	15
Technical data.....	17
Scale drawing	18

Installation and Start-up

Installation location	19
Installation.....	19
Estimation of the required pressure level.....	20
Installation.....	20
Electrical connection	21
Pin assignment of the sensor connection	21
Analog current outputs (4 ... 20 mA) – measurement without load resistance	22
Analog current outputs (4 ... 20 mA) – measurement with load resistance	22
Digital input	23
Determination of the required load resistance.....	23

Switching output	24
Conversion of analog current output to atomic number.....	25
Sequential data output.....	26
Sequential	26
Sequenziell2	27
Start-up	27

Operation of the Particle Counter

Navigation on the menu.....	28
Menu tree.....	29
Selecting the operating mode	30
Configuring alarms.....	32
Configuring analog output.....	33
Selecting a standard	33
Configuring flow rate.....	34
Selecting communication.....	34
Configuring the display	35
Sensor parameters	36
Setting the language.....	36
Calibration.....	37

Communication Settings

Configuration of the serial interface	38
Interface parameters	38
Command list: Read commands	39
Communication via USB.....	39
CANopen	40
CAN J1939	47

Appendix

Troubleshooting	48
Error Code	50
Errors on the display.....	51

Safety

The product was manufactured according to the generally-recognized rules of technology. Nevertheless, there is a danger of personal injury and property damage if you do not heed this chapter and the safety instructions in this documentation.

- Read this documentation thoroughly and completely before you work with the product.
- Keep the documentation so that it is accessible to all users at all times.
- If you give the product to a third party, make sure you also hand over the required documentation.

ENG

Display of safety instructions

So that you can work quickly with this documentation and safely with your product, uniform safety instructions, symbols, terms, and abbreviations are used. For better understanding, these are explained in the following sections.





Safety instructions

This documentation contains safety instructions before a sequence of actions where there is a danger of personal injury or property damage. The measures described to avert danger must be adhered to.

Safety instructions are structured as follows:

⚠ Signal word
<p>Type and source of danger Consequences in case of non-adherence</p> <ul style="list-style-type: none"> • Measure to avert danger • <Enumeration>

- **Warning:** Makes readers aware of the danger
- **Signal word:** Specifies the severity of the danger
- **Type and source of danger:** Specifies the type and source of danger
- **Consequences:** Describes the consequences of non-adherence
- **Prevention:** Specifies how you can handle the danger

Warning sign, signal word	Meaning
 Danger	Identifies a dangerous situation in which death or severe bodily injuries <i>will</i> occur if the danger is not avoided.
 Warning	Identifies a dangerous situation in which death or severe bodily injuries <i>could</i> occur if the danger is not avoided.
 Caution	Identifies a dangerous situation in which mild to moderate bodily injuries could occur if the danger is not avoided.
 Notice	Identifies property damage: The product or its surroundings can be damaged.

ENG

Table: *Meaning of the warning sign*

General safety instructions

- Heed the valid regulations for accident protection and environmental protection.
- Heed the safety regulations and provisions of the country in which the product is used/applied.
- Use HYDROTECHNIK GmbH products only if they are in technically perfect condition.
- Heed all instructions on the product.
- People who install, operate, uninstall or maintain HYDROTECHNIK GmbH products may not be under the influence of alcohol or other drugs or medications that influence the ability to react.
- Use only accessory and spare parts approved by the manufacturer in order to exclude danger to people due to unsuitable spare parts.
- Adhere to the technical data and environmental conditions specified in the product documentation.
- If in safety-relevant applications unsuitable products are installed or use, unintended operating conditions can arise in the application, which can cause personal injury or property damage. Therefore, only use a product in safety-relevant applications if these are explicitly specified and permitted in the product documentation.
- You may only start the product up if it has been determined that the end product (for example, a machine or system) in which the HYDROTECHNIK GmbH products are installed complies with the country-specific provisions, safety regulations, and standards of the application.

Dangerous electrical voltage



⚠ Caution

Dangerous electrical voltage

- Never cut, damage or modify the connector cables or place things on them.
- Never touch the instrument with wet or moist hands.
- Only connect the instrument to power supplies for which it is suited (see technical data).
- Unplug the power cable from the outlet during a thunderstorm.
- Unplug the power cable if you detect smoke or there is an odor, or if the power cable is damaged.
- Ensure sufficient grounding of your system. Inadequate grounding may cause incorrect measurements.

ENG

Laser

⚠ Caution

Laser

The particle counter contains a laser, which with proper use is classified as a Class 1 laser according to DIN EN 60825-1:2001-11. The accessible laser beam is not dangerous under reasonably foreseeable conditions.

- For Class 1 laser equipment, in the upper performance range, blinding, compromising of color vision, and disruptions cannot be excluded.
- Do not remove any covers or panels.

Property damage

Notice

Danger due to improper handling

- The particle monitor may only be used according to proper use.

Notice

Escaping or spillage of hydraulic fluid

Environmental contamination and contamination of the ground water

- Do not use oil binders to bind escaped hydraulic oil.

Notice

Contamination due to liquids and foreign bodies

Premature wear, malfunctions, danger of damage, property damage:

- During installation, pay attention to cleanliness in order to prevent foreign bodies such as beads of sweat or metal chips from getting into the hydraulic lines and causing wear and malfunctions in the product.
- Make sure that connections, hydraulic lines, and detachable parts (e.g. measurement instruments) are free of dirt and chips.
- Before start-up, check whether all hydraulic and mechanical connections are connected and tight, and ensure that all gaskets and seals of the plug connections are inserted correctly and undamaged.
- Use residue-free industrial cloths to wipe away lubricants and other contaminants.
- Make sure that connections, hydraulic lines, and detachable parts are clean.
- Make sure that no contaminants penetrate when sealing the connections.
- Make sure that no cleansers penetrate the hydraulic system.
- Do not use cleaning rags or cloths with fibers for cleaning.
- Do not use hemp as a sealant.

Notice

Handle the instrument carefully

- Never expose the instrument to excessive heat or moisture and observe the technical data.
- Do not store the instrument in humid or dusty locations or at temperatures below freezing point.
- Never submerge the instrument into water or other liquids. Never let liquids come into the instrument.
- Never open the instrument.
- Do not use the instrument if it has been dropped or if the casing is damaged.
- Avoid strong magnetic fields. Keep the instrument away from electric motors or other devices that generate electromagnetic fields. Strong magnetic fields may cause malfunctions and influence measurement values.
- Prevent the formation of condensation. If condensation has formed, let the instrument acclimate before you switch it on. Otherwise it can be damaged.

Pressure equalization membrane

Notice

Functional limitation

Compromising of the IP65 protection class due to damage of the pressure equalization membrane.

- On the rear of the instrument there is a pressure equalization membrane (A) that may not be damaged under any circumstances. When working on the rear, proceed with caution.



A Pressure equalization membrane

Picture: Bottom of particle measuring instrument

Warning stickers on the instrument

To identify danger areas, warning stickers are affixed to the instrument. This section displays and explains the warning stickers used.

ENG



A Notice about laser radiation

Picture: Notice about laser radiation



A Notice about laser class

Picture: Notice about laser class

Introduction



Do not lose out on any claims

The information contained in this section is important. If you neglect it, you might lose the right to make guarantee and warranty claims.

ENG

Scope

This manual is valid for instruments designated **Patrick**. It is intended for the operator of the instrument, that means the person who works with the instrument. This is not a technical manual. Please contact our customer service in case you have questions that go beyond the contents of this manual.

Copyright

The instrument and this manual are protected by copyright. Reproduction without license will be prosecuted. All rights reserved to this manual; this includes the reproduction and/or duplication in any conceivable form, e.g. by photocopying, printing, on any data recording media or in translated form. Reproduction of this manual is only permitted with written approval from HYDROTECHNIK GmbH.

The technical state at the time of delivery of the instrument and the manual is decisive if no other information is given. We reserve the right to make technical changes without special announcement. Earlier manuals are no longer valid.

The general conditions of sale and delivery of HYDROTECHNIK GmbH apply.

Limitation of liability

We guarantee the faultless functioning of our product in accordance with our advertising, the product information we publish and this manual. Additional product properties are not assured. We assume no liability for the economy and faultless function if the product is used for a different purpose than the one described in the chapter **Intended use**.

Compensation claims are generally excluded, except if intention or culpable negligence by HYDROTECHNIK GmbH is proved, or if product features promised are not provided.

If the product is used in environments for which it is not suited or that do not represent the technical standard, we shall not be responsible for the consequences. We assume no liability for damage to installations and systems in the surroundings of the product that is caused by a fault of the product or an error in this manual. We are not responsible for the violation of patents and/or other rights of third persons outside the Federal Republic of Germany.

We are not liable for damage that results from improper operation and non-compliance with the instructions in this manual. We are not liable for lost profits and for consequential damages that arise from non-compliance with safety and warning information. We assume no liability for damage that results from the use of accessories and wearing parts that were not delivered and/or approved by HYDROTECHNIK GmbH.

The products of HYDROTECHNIK GmbH are designed for a long life. They represent the state of the art and their functions have been individually checked before delivery. The electrical and mechanical design corresponds to current standards and regulations. HYDROTECHNIK GmbH conducts ongoing product and market research for the further development and continuous improvement of its products.

In case of faults and/or technical trouble, please contact HYDROTECHNIK GmbH customer service. We can assure you that we will take immediate measures. The guarantee conditions of HYDROTECHNIK GmbH apply; if desired, we will gladly send you these.

Intended use

The instrument **Patrick** is an optical particle monitor that is used to monitor the purity of fluids. It works according to the principle of light extinction and detects particles and other foreign bodies in fluid. The values measured are converted into standardized purity classes and shown on the display.

Using a serial interface, the measurement data can be read out and transferred to a measuring instrument. Connection to the fluid-conducting system is made via two MINIMESS[®] test points of the screw series 1620.

Any other use of this instrument is considered improper.

If you have any questions or you want to use the instrument for a different purpose, please do not hesitate to contact our customer service. We will be happy to assist you with any possibly necessary configurations.

ENG

Warranty

In accordance with our warranty conditions, we guarantee the condition without defects of this instrument for a duration of six months. Wearing parts and storage batteries are excluded from this warranty. The warranty becomes void if repair work or interventions are executed by unauthorized persons.

Within the warranty period we will repair damage or defects that are caused by a manufacturing fault. We only accept warranty claims if they are reported to us immediately after their discovery, but no later than six months after delivery. The warranty benefit is by our choice through free repair of defective parts or replacement with sound parts.

Please send the instruments for which you have made a warranty claim postage-paid and with a copy of the invoice or the delivery slip to HYDROTECHNIK GmbH customer service. You can find the address at the end of this manual.

Customer obligations

The operator of this product must ensure that only persons who

- know the regulations concerning occupational safety and accident prevention
- have been instructed in the operation of this product
- have read and understood this manual

are permitted to operate this instrument.

Persons who operate this instrument are obliged to

- obey all regulations on occupational safety and accident prevention
- read this manual completely, especially the safety instructions in the first chapter.

ENG

Authorized personnel

Persons are considered to be authorized if they have a professional education, technical experience, knowledge of the relevant standards and regulations and if they are able to estimate their duties and recognize possible danger at an early time.

Operator of the instrument

Persons are considered to be authorized if they have been instructed in the operation of the instrument and have read and understood this manual completely.

Personnel for installation and maintenance

Persons are considered to be authorized if they have been trained in all aspects of the instrument and have read and understood this manual completely.

Disposal



Disposal information

Do not dispose of this product with your household waste.

You can find more detailed information on disposal on our website at: www.hydrotechnik.com.

Description of the Instrument

Properties

ENG

The instrument **Patrick** is an optical particle monitor that works according to the light extinction principle:

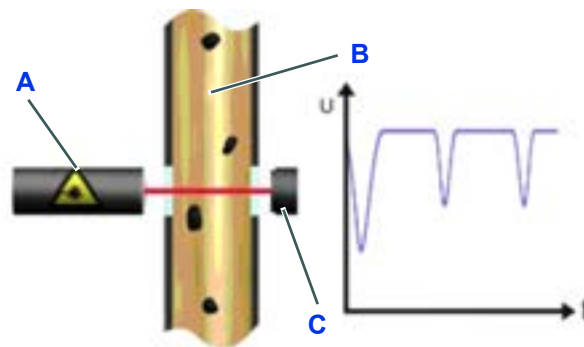

A Laser
B Measurement cell
C Photodiode

Picture: Functional principle:

It consists of a measurement cell (B), a laser (A) and a photodiode (C). The laser irradiates the measurement cell and hits the photodiode. If a particle passes through the laser beam, the intensity reflected by the photodiode is reduced. The larger the particle, the stronger the reduction of the light intensity.

With **Patrick** the contamination level and the trend of the purity of fluids can be examined. Here, in the absolute precision, there can be differences with respect to particle counters that are calibrated according to ISO 11171:99. However, the deviation is smaller than one atomic number. Changes are displayed very precisely. Thanks to the continuous monitoring of the purity, changes in a machine can be detected very quickly. Thus measures can be taken in order to prevent further contamination and damage to the overall system.

The display of the purity class is optionally according to ISO 4406:99, SAE AS4059E, NAS 1638 or GOST 17216. The instrument measures the temperature; this is not measured in the oil, but rather on the electronics board (measurement range -20 ... 100 °C). The instrument has an operating hours counter whose values are still present even after power failure. After the interruption, the counter starts counting again at the last saved time value before the interruption.

Online measurement on the computer

After connecting **Patrick** to a computer, it is possible using the HYDROTECHNIK GmbH software **HYDROcom 6** to display the current measurement data on the PC and save it there.

Please heed the **HYDROcom 6** online help for further instructions.

Components of the Instrument

ENG



- | | |
|------------------------------------|-------------------------------|
| A Fluid supply | F Fluid drain |
| B Pivoting instrument front | G Enter key |
| C Power light | H Page up key |
| D Alarm light | I Page down key |
| E Display | J Escape key |

Picture: Front view

- Fluid supply (A) / Fluid drain (F)** The instrument is equipped with two MINIMESS[®] test points of the 1620 series. Normally, two MINIMESS[®] hose connections are connected here with which the particle counter is connected to the fluid-carrying system. The measurement is regardless of the flow direction.
- Display (B) / (E)** The front side of the instrument can be pivoted up to 180° so that it is always possible to orient horizontally regardless of the mounting of the display. The last determined purity classes are shown on the software display, as well as the time to the next measurement or the remaining time of the measurement.
- Power light (C)** This light lights up green to indicate whether operating voltage is flowing.
- Alarm light (D)** This light indicates the presence of an alarm by light up red. In the instrument, three alarms can be programmed; for this, follow the instructions in these operating instructions.
- Keys (G) ... (J)** The entire operation and programming is done with four keys:



Calls up the main menu from the measurement value display
 Moves the highlighting up
 Increases a number in an input field



Calls up the main menu from the measurement value display
 Moves the highlighting down
 Reduces a number in an input field



Selects menu entries from and open submenus
 Confirms the entries
 Jumps to the next number in an input field



Jumps one menu level up
 Exits the main menu
 Cancels entries

Technical data

Operating conditions

Permissible operating pressure	420 bar (dynamic) 600 bar (static)
Ambient temperature	-20 ... 80 °C
Humidity	0 ... 95 %

Storage conditions

Ambient temperature	-20 ... 85 °C
Humidity	0 ... 95 %

Fluids

Permissible fluids	Mineral and ester fluids, polyalphaolefins
Fluid temperature	-20 ... 80 °C
Fluid connections	2x 1/4" MINIMESS® 1620
Permissible flow rate	50 ... 400 ml/min
Moistened materials	Stainless steel, sapphire, NBR, chrome
Sealing material	NBR
Power supply	9 ... 33 V DC
Current consumption	Max. 300 mA
Current outputs	4 ... 20 mA
Interfaces	RS 232, CANopen
Alarm contact	Potential-free contact
Electrical connection	8-Pin plug M12 x 1
Measurement range according to ISO 4406:99	0 ... 24 (atomic number)
Calibrated measurement range	10 ... 22 (atomic number)
Measurement precision	± 1.0 (atomic number)
IP-Code	IP 65

Table: *Technical data*

Scale drawing

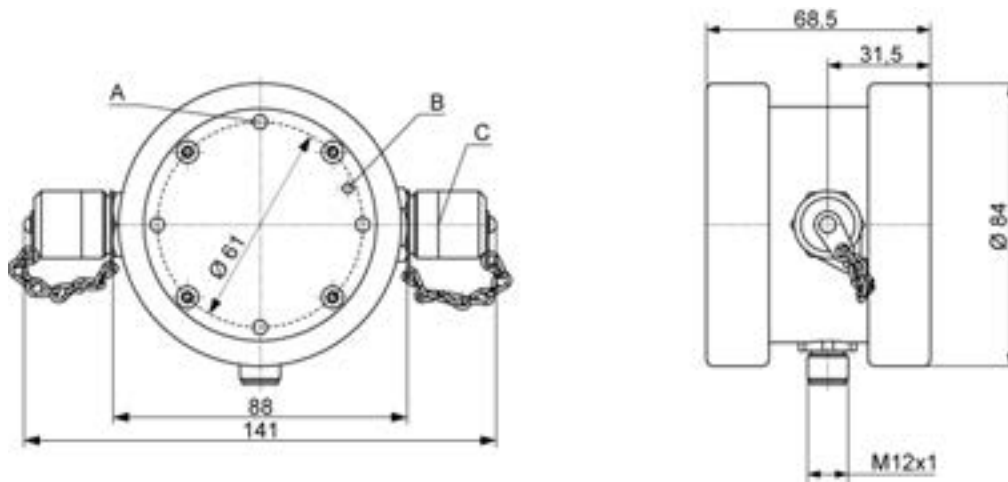

- A** Four fastening points M5 x 5.5
- B** Ventilation opening with pressure equalization element (fastened from the inside)
- C** 2 x MINIMESS® test points 1620, 2103-01-18.00N

Picture: Scale drawing

ENG

Installation and Start-up

Installation location

ENG

Please follow these instructions for specifying the installation location:

- Connect **Patrick** via T-branching on the auxiliary current to a pressure line.
- The flow direction is arbitrary.
- Pressure conditions that are as constant as possible should prevail at the connection point. The pressure can vary, however there may be no pressure peaks or sharp fluctuations.
- The connection to the control line is recommended; alternatively, the filter or coolant circuit is possible.
- The volumetric flow should be constant and be between 50...400 ml/min.
- Flow control and pressure reduction should always be installed after the particle counter since such equipment can generate particles and air bubbles that would cause measurement errors.
- If a pump is required to generate the required flow, it should be designed so that it is low-pulsation and installed in front of the particle counter. Otherwise with arrangement on the intake side, bubbles can be generated that would cause measurement errors.

Installation

Note these additional instructions before installation:

- During installation, make sure that the display is easy to read. To make things easier, the display can be pivoted 180°.
- For connection lines, the shorter the better. With the length of the line, the danger of settling larger particles increases.
- Especially with higher viscosities and the use of MINIMESS® hoses, make sure that the pressure is high enough to set a volumetric flow between 50 ... 400 ml/min.
- Make sure that the fluid measured is bubble and drop-free. You can usually detect bubbles and drops in the oil from high atomic numbers or the same atomic numbers in different size channels. Such bubbles and drops cannot be detected with the naked eye.

Estimation of the required pressure level

Pay attention to the p of the particle counter depending on the viscosity of the fluid:

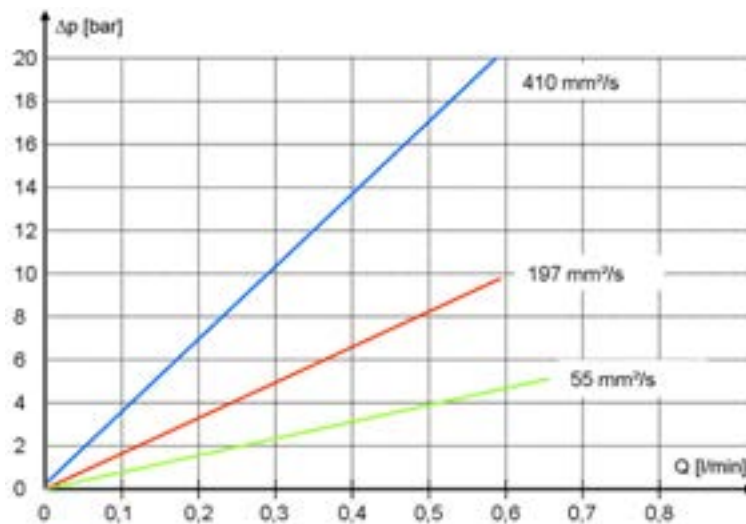

Picture: Δp -Q characteristic curve for different viscosities

From this you can estimate the required pressure level for the required volumetric flow of 50...400 ml/min.

Installation

→ Now you can install **Patrick**:

- 1 Identify an installation location that corresponds to the criteria named above.
- 2 Connect two fluid lines tot the two MINIMESS[®] test points.
- 3 Fasten the particle counter using the fastening points on the rear of the instrument.



Electrical connection

The instrument may only be installed by a trained electrician. Note the national and international regulations for the set-up of electrotechnical systems and lay the power supply according to EN 50178, SELV, PELV, VDE0100-410/A1. Use the HYDROTECHNIK GmbH power supply 8812-00-00.36 in connection with the Y-distributor 8808-50-01.03.

De-energize the system for the installation of the system and connect the instrument as follows.

ENG

Pin assignment of the sensor connection

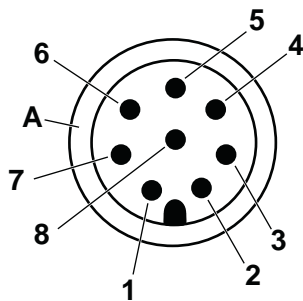

Pin	Function
1	+U _B
2	GND
3	TxD, CAN-L
4	RxD, CAN-H
5	Digital Input
6	IOUT1
7	Open Collector, Alarm OUT
8	SGND
A	Housing / screen

Table: Pin assignment, top view of the sensor cover

The permissible operating voltage is between 9...36 VDC. Use only screen sensor cables. In order to achieve the protection class IP 65, only suitable plugs and cables may be used. The maximum tightening torque for the plug is 0.1 Nm.

Analog current outputs (4 ... 20 mA) – measurement without load resistance

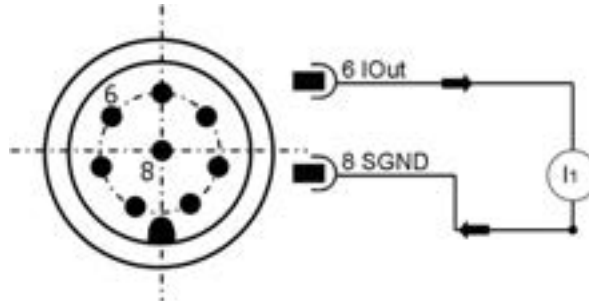

Picture: Measurement of the analog 4...20 mA output without load resistance

Perform the current measurement with a suitable measurement instrument. The assignment of the measured current value to the characteristic curve will be explained in detail below.

Analog current outputs (4 ... 20 mA) – measurement with load resistance

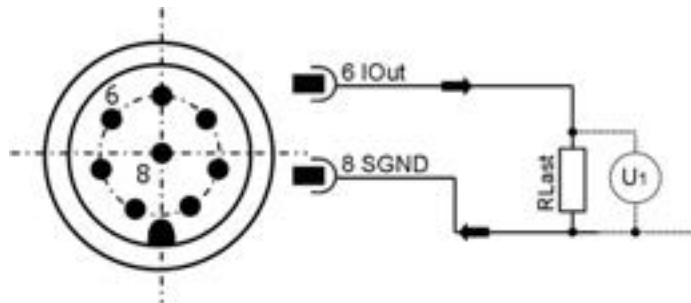

Picture: Measurement of the analog 4...20 mA output with load resistance

In order to be able to measure the current of the two analog current outputs, a load resistance must be connected to each output. The load resistance should, depending on the supply voltage, be between 250 and 2,600 . With a voltmeter, you can measure the voltage that drops off over the load in question.

With the formula described in **Switching output** on page 24 you can determine the atomic number of the purity class from the voltages measured.

Digital input

The digital input is *HIGH – active*. It is active as soon as there is supply voltage and *floats* when there is no voltage.

A measurement lasts as long as the digital input is NOT connected to ground. If the input is connected to ground, there is a current of

$$I = (U - 1.1 \text{ V}) / 5,600 \ \Omega$$

With U = supply voltage.

ENG

Determination of the required load resistance

The load resistance cannot be chosen arbitrarily. Adjust it according to the supply voltage of the sensor. Calculate the maximum load resistance either with the following formula or take it from the table below.

Formula	U _V in V	R _{max} in Ω
$R_{\max} = \frac{U - 2V}{20mA} - 100\Omega$	9	250
	12	400
	18	600
	24	1,000
	30	1,300

Table: *Determination of the required load resistance*

Switching output

The switching output is not short-circuit-proof, it has no overcurrent or over-temperature fuse.

The maximum switching voltage is 36 VDC.

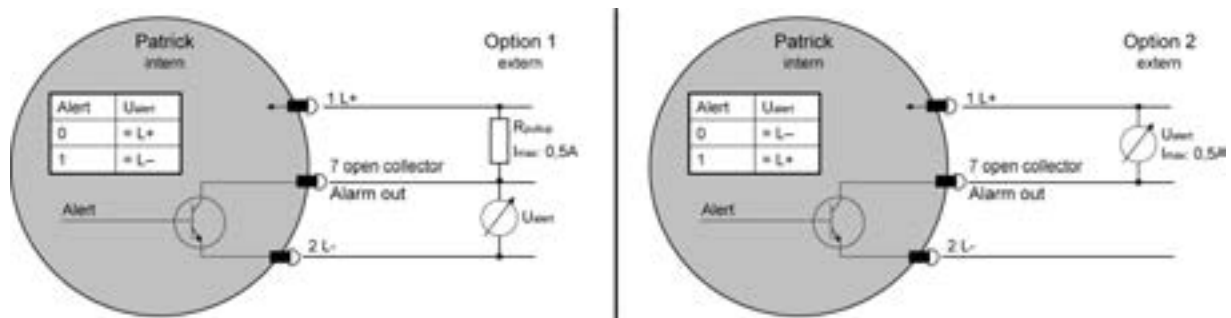

Picture: Switching output

Option 1	
Internal	External
Alert	U _{alert}
0	= U+
1	= 0

Option 2	
Internal	External
Alert	U _{alert}
0	= 0
1	= U+

ENG

Conversion of analog current output to atomic number

The analog current output provides a signal from 4 ... 20 mA. The conversions for the respective atomic numbers are described below.

I/mA	ISO 4406:99	SAE AS4059E
4	0	000
12	13	5
20	26	12

Table: Comparison table current output to atomic number ISO and SAE.

I/mA	NAS 1638	GOST 17216
4	00	00
12	7	15
13	8	17
14	9	-
15	10	-
16	11	-
17	12	-
20	-	-

Table: Comparison table current output to atomic number NAS and GOST

Standard	Atomic number formula
ISO 4406:99	$1.625 * I/mA - 6.5$
SAE AS4059E	$0.875 * I/mA - 5.5$
NAS 1638	$I/mA - 5$
GOST 17216	$2 * I/mA - 9$

Table: Conversion of atomic numbers

Sequential data output

For the standards ISO 4406:99 and SAE AS4059E, you can select a sequential data output.

There are two modes for the sequential data output:

- **Sequential**
- **Sequenziell2**

Sequential

After a start sequence (S), the measurement values for the different size classes are transmitted one after another. After a pause, the next cycle begins with the transmission of the start sequence.

For NAS and GOST, no sequential output is available.

Sequence 1 - 5

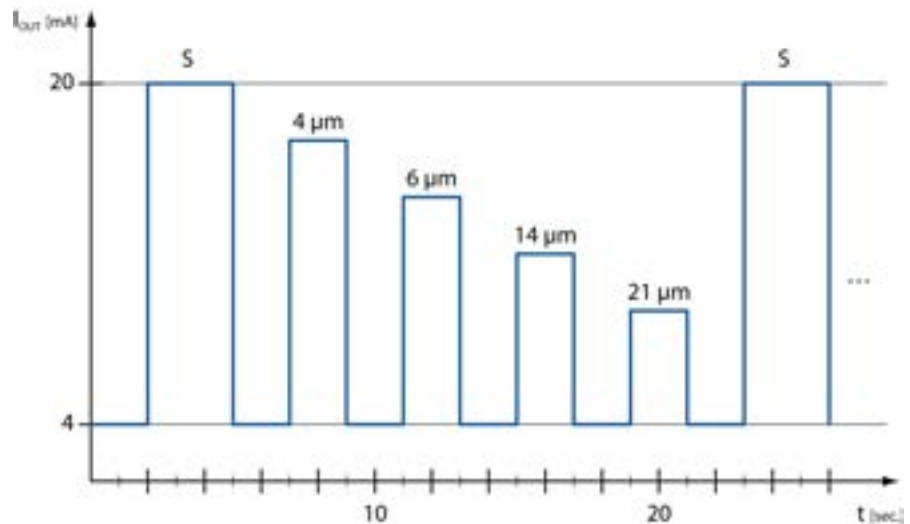

Picture: Sequence for the output of all parameters one after another

Sequenziell2

The **Sequenziell2** mode is an expansion of the **Sequenziell** mode. The expansion consists of the three following sequences:

Sequence 6

Meaning	I/mA							
	5	7	9	11	13	15	17	19
Flow too low ERC 1, Bit 10	1	1	1	1	0	0	0	0
Flow too high ERC 1, Bit 9	1	1	0	0	1	1	0	0
Error in measurement cell ERC 4, Bit 0, 1, 2 or 3	1	0	1	0	1	0	1	0

Sequence 7

Meaning	I/mA							
	5	7	9	11	13	15	17	19
Concentration too low ERC 1, Bit 14	1	1	1	1	0	0	0	0
Concentration too high ERC 1, Bit 8	1	1	0	0	1	1	0	0
Measurement result not plausible ERC 1, Bit 13	1	0	1	0	1	0	1	0

Sequence 8

Meaning	I/mA							
	5	7	9	11	13	15	17	19
Alarm concentration ERC 4, Bit 14	1	1	1	1	0	0	0	0
Alarm temperature ERC 4, Bit 15	1	1	0	0	1	1	0	0
ISO(i+1) ≥ ISO(i) ERC 1, Bit 11	1	0	1	0	1	0	1	0

⇒ List of all ERCs: **Error Code** on page 50

Start-up

The particle counter starts the measurements right away and, after a minute, outputs the first measurement results on the display.

Operation of the Particle Counter

Navigation on the menu

Here's how the operating keys are programmed:



Calls up the main menu from the measurement value display
Moves the highlighting up
Increases a number in an input field



Calls up the main menu from the measurement value display
Moves the highlighting down
Reduces a number in an input field



Selects menu entries from and open submenus
Confirms the entries
Jumps to the next number in an input field



Jumps one menu level up
Exits the main menu
Cancels entries

Menu tree

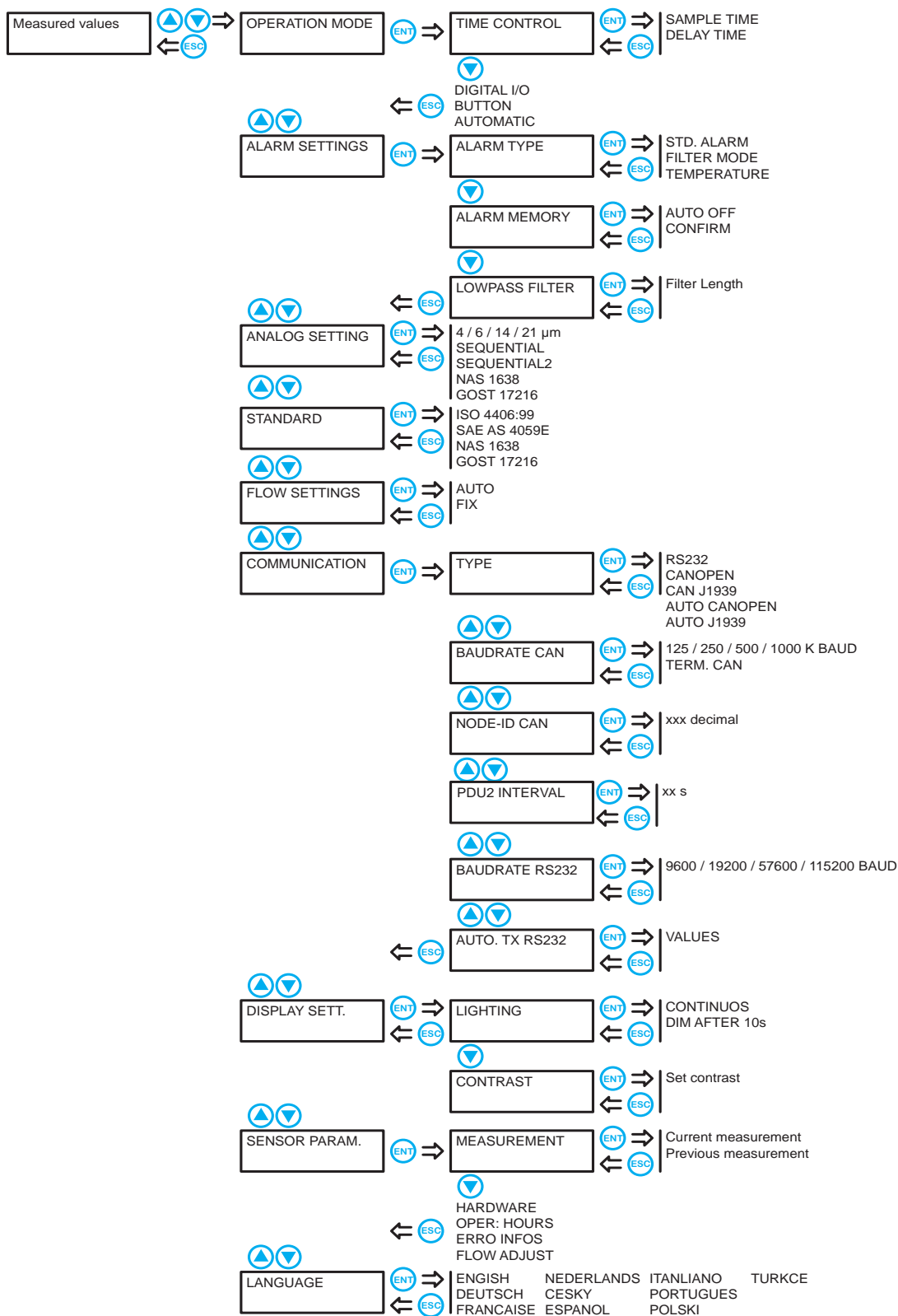

The individual submenus and functions are described chronologically below.

Selecting the operating mode



Heed minimum measurement duration

The measurement duration should always be at least 30 seconds; otherwise, under some circumstances, the particle count cannot be recorded completely. The cleaner the oil is, the longer it should be measured. Purity grades according to ISO 4406:99 of 15 and better should be re-measured at least every 120 seconds.

ENG

Patrick can be used in three operating modes:

<p>Timer</p>	<p>Patrick works with the set measurement duration and wait time between the measurements.</p> <p>Example: one minute measurement duration and four minutes wait time produces a result every five minutes. In fact, it takes two to three seconds longer since the laser is regulated at the beginning of each measurement.</p> <p>With activated and marked Timer option, press ENT again to set the measurement duration and wait time:</p> <ul style="list-style-type: none"> Measurement duration: <ul style="list-style-type: none"> Press ENT to start the entry. Arrows appear next to the first digit. Press ▲ ▼ to set the first digit. Press ENT to change to the next digit. Set all of the digits of the measurement duration this way, confirm with ENT and press ESC. Wait time: <ul style="list-style-type: none"> Set the desired wait time as described for the measurement duration
<p>Digital I/O</p>	<p>The measurement lasts as long as there is a signal on the input. The digital input is active if it is connected to a ground. Then there is a current of</p> $I = (U - 1.1 \text{ V}) / 5600 \Omega$ <p>With U = supply voltage.</p>

Key	Press the  key to start and end a measurement.
Automatic	<p>In automatic mode, the measurement time is determined dynamically, depending on the flow and the particle concentration.</p> <p>The measurement can last between 45 and 300 seconds. A measurement value should be awaited at the earliest after 45 seconds if in this time the defined number of particles was detected. If the defined number of particles has also not been detected after 300 seconds, the measurement is cancelled and the result displayed. The result is then not backed up statistically.</p>

ENG

Configuring alarms

Alarm type First you select the alarm type here:

Std. Alarm	As soon as a channel exceeds a set threshold, the alarm is triggered.
Filter mode	Serves to monitor a cleaning: As soon as all activated channels have dropped below a threshold, the alarm is triggered.
Temperature	As soon as the temperature exceeds the set threshold, the alarm is triggered. In order to deactivate the alarm, the limit value must be 00 . The measured temperature does not correspond directly to the temperature of the oil.

ENG

Activate the desired alarm type with **ENT** and then press **ENT** again to display the alarm thresholds:

STD. ALARM			
0/	0/	0/	0

Press **ENT** to start the entry. Arrows appear next to the first “zero”. Press **▲** **▼** to set the first alarm threshold. Press **ENT** to change to the next size class. Set the alarm thresholds this way for all size classes. If one should not be considered, set its value to **0**.

The thresholds set for the standard alarm also apply for the filter mode, and vice-versa.

Alarm memory Here you select the behavior of **Patrick** when an alarm is present. This can either be switched off automatically (**Autom. off**), or it can remain active up to an acknowledgement by keypress (**Confirm**).

Deep-pass filter In a hydraulic system, short-term concentration increases (peaks) can occur, which are not representative for the overall system. The particle counter detects this change and displays these correctly.

The deep-pass filter ensure that for a set alarm threshold, an alarm is not triggered for each peak. The particle concentrations relevant for the alarm are smoothed internally and an alarm is only output in case of a long-lasting measurement change. The measurement value output and display are not affected by the filtering.

- With a volumetric flow of 0 ml/min or an ISO class of 0 to 4 μm, the filter function is deactivated automatically.
- Adjustment range: 1 ... 255 (1 = deactivated)
- Factory setting: 2
- Recommended value: ≤10

Configuring analog output

Here you select which data should be output via the analog output:

<p>4 μm 6 μm 14 μm 21 μm</p>	<p>Select a size class whose measurement value should be output via the analog output.</p> <p>The output is done in whole atomic numbers (4 mA corresponds to the atomic number “zero”, 20 mA to the atomic number “26”).</p> <p>The output depends on the set standard, ISO or SAE.</p> <p>The maximum working resistance depends on the supply voltage:</p> $R_{max} = \frac{U - 2V}{20mA} - 100\Omega$
<p>Sequential</p>	<p>The measurement values of all size classes are output one after another.</p> <p>⇒ Sequential on page 26</p>
<p>Sequenziell2</p>	<p>The measurement values of all size classes are output one after another. Alarms are also output.</p> <p>⇒ Sequenziell2 on page 27</p>
<p>NAS 1638</p>	<p>Output regardless of set standard. On the LCD, ISO, SAE or GOST can be displayed; however, via the analog output, NAS is output.</p>
<p>GOST 17216</p>	<p>Output regardless of set standard. On the LCD, ISO, SAE or NAS can be displayed; however, via the analog output, GOST is output.</p>

ENG

Selecting a standard

The display of the purity can be selected according to one of the following standards:

- ISO 4406:99
- SAE AS4059E
- NAS 1638
- GOST 17216

For the display according to SAE, ensure that the size classes 38 and 70 μm are not evaluated on separate channels, but together with the size class 21.

The setting refers only to the display on the start screen. In the internal memory and for the output via the digital interface (CAN or RS232), all standards are visible.

You can tell which standard is selected in the bottom left of the start screen.

Configuring flow rate

Patrick In addition to the particle size and number, also records the flow rate in order to calculate the concentration from this. This happens if the **Auto** option is set (recommended flow rate: 100 ... 400 ml/min).

However, since each measurement is afflicted with imprecision, you can permanently set a known flow rate. The concentration is then calculated from this. Set the **Fix** option and then press **ENT** again:

FIX
050 ml/min

Press **ENT** to start the entry. Arrows appear next to the first digit. Press **↓** **↑** to set the first digit. Press **ENT** to change to the next digit. Set the flow rate this way.

Select a flow rate that is similar to the actual flow rate. In case of a larger deviation, the calculated concentration is falsified.

ENG

Selecting communication

Here you define the configuration of the digital interface.

Select type of the interface

RS 232	Output of the data via the RS232 interface.
CANopen	Output of the data via CAN bus in the CANopen protocol.
CAN J1939	Output of the data via CAN bus in the J1939 protocol.
Auto CANOPEN^(a)	The connected interfaces are detected automatically. If the CAN type is detected, the CANopen protocol is used.
Auto J1939^(a)	The connected interfaces are detected automatically. If the CAN type is detected, the CAN J1939 protocol is used.

^(a)For the type **Auto** the type is determined using the physical voltage level on the digital interface. The determination is done once when switching the particle counter on.

CAN baud rate Select the speed of the data transmission via the CAN interface. The selected speed must match that of your CAN bus; otherwise communication is not possible.

50 / 125 / ...	Select the speed in kBaud.
Term. CAN	Switches on a 120 Ω resistance for termination of the CAN line. This option should always be activated.

Node-ID CAN Here you can display the set Node-ID of the particle counter. You need this in order to correctly address CAN commands or to assign CAN signals correctly.

PDU2 Interval You can set the interval with which the PDU2 is sent here. PDU2 is only used with CAN J1939.



Baud rate RS 232 Select the speed of the data transmission via the RS 232 interface. The selected speed must match that of your system; otherwise communication is not possible.

Automatic send Here, you can set whether the measurement values are sent automatically via the RS232 interface.

ENG





Configuring the display

A variety of display styles are available for the display.

- **Lighting:**
Selection whether the background lighting should be permanently active or whether it should be deactivated automatically after 10 seconds.
- **Contrast:**
Adjustment of the contrast via a bar display.
 -  = increase contrast
 -  = reduce contrast
 -  = confirmation

Sensor parameters

With this menu element, you can display various parameters of the particle counter:

Measurement results	<p>Displays the last measurement results of the size glasses and the index of the volumetric flow.</p> <p>Press  to switch the display between the size classes.</p> <p>Press  to display the previous measurement result.</p>
Electronics	<p>Displays various measurement values of the electronics.</p> <p>Press  to display additional parameters.</p>
Operating hours	<p>Displays the number of operating hours of sensor and laser.</p>
Error info	<p>Displays a list of the error messages and alarms that have occurred.</p> <p>Press   to page through the available messages.</p>
Set flow	<p>Here the level of the volumetric flow is displayed.</p> <ul style="list-style-type: none"> • If the bar is between L and H, the volumetric flow is OK. • If the bar fills the entire diagram or if no bar is visible and H/L is flashing, the volumetric flow is too high or too low and it must be adjusted. <p>The limits of the display (bar diagram) are between L = 50 ml/min and H = 400 ml/min.</p> <p>The display is updated every 10 seconds.</p> <p>If the FIX flow is set to a static value, this is also displayed. However, the bar will not change.</p>

ENG

Setting the language

Select one of the available languages for the display of the operating menu.

Calibration

The particle counter is calibrated relying on ISO 11943.

The equipment that is used for the calibration is calibrated first according to ISO 11171 and can thus be traced back to NIST SRM 2806A.

The calibration certificate of the particle counter has an initial validity of 18 months. Subsequent certificates will be issued with a validity of 12 months.

Calibration note The particle counter indicates the need for calibration with a message on the display.

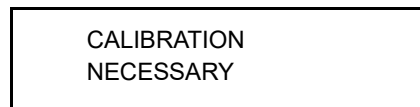

Have the particle counter calibrated by the manufacturer.

- Press the **ENT** input key for 2 seconds to acknowledge the message.
- The message appears again after 500, 800 and 900 hours.
- After 1000 hours, the message flashes at a 2-second interval.
- However, the particle counter can be operated completely and provides measurement results at all times

You can see the remaining hours up to the appearance of the first message (**HOURSCAL**) on the particle counter's menu under *SENSORPARAM > OPERATING HOURS*.

Communication Settings

Configuration of the serial interface

ENG

Patrick can be read out and configured using a serial interface. For this you need a PC with the installed terminal software.

Connect **Patrick** to a free COM port on the computer. A suitable communication cable for the serial connection between sensor and PC/controller is available as an accessory. If the computer has no standard COM port, it is possible to use a serial interface card or a USB-serial converter.

Interface parameters

- Baud rate: 9600 / 57600
- Data bits: 8
- Parity: none
- Stop bits: 1
- Flow control: None

Command list: Read commands

Command	Meaning	Return format
RVal[↵]	Reading of the current measurement value with subsequent checksum (CRC)	\$Time:%.4f[h];ISO4µm:%i[-];ISO6µm:%i[-];ISO14µm:%i[-];ISO21µm:%i[-];SAE4µm:%i[-];SAE6µm:%i[-];SAE14µm:%i[-];SAE21µm:%i[-];Conc4µm:%.2f[p/ml];Conc6µm:%.2f[p/ml];Conc14µm:%.2f[p/ml];Conc21µm:%.2f[p/ml];FIndex:%i[-];Mtime:%i[s];Status:0x0000; 0x0000;0x0000;0x0000;CRC:x
RMemS[CR]	Reading of the storage-capable data records	MemS: xxxx[CR][LF]
RMemU[CR]	Reading of the number of stored data records	MemU: xxxx[CR][LF]
RMem[↵]	Reading of all saved measurement values	Time [h]; T [°C]; P [-];P40 [-];PTG [1/K];... [CR][LF] x.xxx;x.xxxx;x.xxxx;x.xxxx; x.xxxx;... [CR][LF]
RID[↵]	Reading of the identification with subsequent checksum (CRC)	Hydrotechnik;Patrick;SN:xxxxxx-xxx; SW:xx.xx.xx;CRC:x 1)
RCon[↵]	Reading of the current configuration	Smode:%i;Fmode:%i;Analog:%i; Amode:%i;Alarm4:%i;Alarm6:%i;Alarm14:%i;Alarm21:%i;(Mtime:%i[s];Htime:%i[s])

Table: Command list: Read commands

Please contact our customer service if you need a complete list of all the commands.

Communication via USB

Patrick can be read out using a USB interface. For this you need a PC with the installed software **HYDROcom 6**.

Connect **Patrick** to a USB port on the computer. A suitable RS 232 - USB converter cable is available as an accessory. Heed the notes in the online help for the **HYDROcom 6** software for additional information.

CANopen

The particle counter can be incorporated into bus systems that correspond to the CANopen standard. For a detailed description of CANopen and the underlying architecture, see the relevant specialized books and textbooks.

CANopen Object Dictionary The table contains the communication-related part of the particle counter's object directory. The possible settings correspond, but for a few exceptions, to the CANopen standard as described in "DS-301".

ENG

Idx	SIdx	Name	Type	Attr.	Standard	Notes
1000h	0	Instrument type	unsigned 32	ro	194h	Sensor, see DS404
1001h	0	Error list	unsigned 8	ro	00h	Obligatory, see DS301
1017h	0	Heartbeat time	unsigned 16	rw	1388h	Heartbeat time in ms, range: 0 ... 65535
1018h		Identity object	record	ro		
	0	Number of entries	unsigned 8	ro	04h	Largest sub-index
	1	Manufacturer ID	unsigned 32	ro	00001C0h	HYDROTECHNIK
	2	Product code	unsigned 32	ro	12D5C74Ch	12D5C74Ch
	3	Version number	unsigned 32	ro	1000	Instrument-dependent
	4	Serial number	unsigned 32	ro		Instrument-dependent
1800h		Transmissions PDO1 parameter	record			
	0	Number of entries	unsigned 8	ro	05h	Largest sub-index
	1	COB-ID	unsigned 32	rw	180h +NodeID	COB-ID of PDO used, range: 181h ... 1FFh, can be changed if switched off (bit 30 must always be set, means no triggered TPDO on RTR)
	2	Transmission type	unsigned 8	rw	FFh	Cyclical + synchronous, asynchronous Values: 1 ... 240, 254, 255
	5	Event time	unsigned 16	rw	1F4h	Event time in ms for asynchronous TPDO1, value must be a multiple of 50 and max 12700

Table: Communication profile (Tabellenabschnitt 1 von 7)

(a) Mapped to PDO

Idx	SIdx	Name	Type	Attr.	Standard	Notes
1801h		Transmissions PDO2 parameter	record			
	0	Number of entries	unsigned 8	ro	05h	Largest sub-index
	1	COB-ID	unsigned 32	rw	280h +NodeID	COB-ID uses from PDO, range: 281H .. 2FFh, can be changed if switched off (bit 30 must always be set, means no triggered TPDO on RTR)
	2	Transmission type	unsigned 8	rw	FFh	Cyclical + synchronous, asynchronous Values: 1 ... 240, 254, 255
	5	Event time	unsigned 16	rw	1F4h	Event time in ms for asynchronous TPDO2 range: 0 ... 65000
1802h		Transmissions PDO3 parameter	record			
				ro		
	0	Number of entries	unsigned 8	ro	05h	Largest sub-index
	1	COB-ID	unsigned 32	rw	380h+NodeID	COB-ID uses from PDO, range: 381H .. 3FFh, can be changed if switched off (bit 30 must always be set, means no triggered TPDO on RTR)
	2	Transmission type	unsigned 8	rw	FFh	Cyclical + synchronous, asynchronous Values: 1 ... 240, 254, 255
5	Event time	unsigned 16	rw	1F4h	Event time in ms for asynchronous TPDO3 range: 0 / 65000	

Table: Communication profile (Tabellenabschnitt 2 von 7)

(a) Mapped to PDO

Idx	SIdx	Name	Type	Attr.	Standard	Notes
1A00h		TPDO1 Mapping Parameter	record			
	0	Number of entries	unsigned 8	ro	05h	Largest sub-index
	1	PDO mapping for first application object to be mapped	unsigned 32	co	20000220h	Operating hours stamp for the measurement, 4 bytes
	2	PDO mapping for second application object to be mapped	unsigned 32	co	20010108h	ISO4 μ m, 1 Byte in 2001h, sub 01
	3	PDO mapping for third application object to be mapped	unsigned 32	co	20010208h	ISO6 μ m, 1 Byte in 2001h, sub 02
	4	PDO mapping for fourth application object to be mapped	unsigned 33	co	20010308h	ISO14 μ m, 1 Byte in 2001h, sub 03
	5	PDO mapping for fifth application object to be mapped	unsigned 32	co	20010408h	ISO21 μ m, 1 Byte in 2001h, sub 04
1A01h		TPDO2 Mapping Parameter	record			
	0	Number of entries	unsigned 8	ro	05h	Largest sub-index
	1	PDO mapping for first application object to be mapped	unsigned 32	co	20000220h	Operating hours stamp for the measurement, 4 bytes
	2	PDO mapping for second application object to be mapped	unsigned 32	co	20020108h	SAE4 μ m, 1 Byte in 2002h, sub 01
	3	PDO mapping for third application object to be mapped	unsigned 33	co	20020208h	SAE6 μ m, 1 Byte in 2002h, sub 02
	4	PDO mapping for fourth application object to be mapped	unsigned 32	co	20020308h	SAE14 μ m, 1 Byte in 2002h, sub 03
	5	PDO mapping for fifth application object to be mapped	unsigned 32	co	20020408h	SAE21 μ m, 1 Byte in 2002h, sub 04

Table: Communication profile (Tabellenabschnitt 3 von 7)

(a) Mapped to PDO

ENG

Idx	SIdx	Name	Type	Attr.	Standard	Notes
1A02h		TPDO3 Mapping Parameter	record			
	0	Number of entries	unsigned 8	ro	05h	Largest sub-index
	1	PDO mapping for first application object to be mapped	unsigned 32	co	20000120h	Operating hours counter, 4 bytes
	2	PDO mapping for second application object to be mapped	unsigned 32	co	20030108h	Operating hours counter, 1 byte
	3	PDO mapping for third application object to be mapped	unsigned 32	co	20030708h	Measurement bits, 1 byte
	4	PDO mapping for fourth application object to be mapped	unsigned 32	co	20030808h	Sensor status bits, 1 byte
	5	PDO mapping for fifth application object to be mapped	unsigned 32	co	20040008h	Temperature, 1 byte
2000h		Time-related sensor parameter	record			
	0	Number of entries	unsigned 8	ro	02h	Largest sub-index
	1	Operating hours counter ¹	unsigned 32	ro		Sensor operating time in seconds
	2	Operating hours stamp for the measurement ¹	unsigned 32	ro		Time stamp for the last measurement
2001h		ISO measurement	record			
	0	Number of entries	unsigned 8	ro	04h	Largest sub-index
	1	ISO4 μm^1	unsigned 8	ro		
	2	ISO6 μm^1	unsigned 8	ro		
	3	ISO14 μm^1	unsigned 8	ro		
	4	ISO21 μm^1	unsigned 8	ro		

Table: Communication profile (Tabellenabschnitt 4 von 7)

(a) Mapped to PDO

ENG

Idx	SIdx	Name	Type	Attr.	Standard	Notes
2002h		SAE measurement	record			
	0	Number of entries	unsigned 8	ro	04h	Largest sub-index
	1	SAE4 μm^1	unsigned 8	ro		Offset of two to be depicted by 000 00 and 0, Applies for all classes: 0 = SAE 000 1 = SAE 00 2 = SAE 0 3 = SAE 1 4 = SAE 2 ...
	2	SAE6 μm^1	unsigned 8	ro		
	3	SAE14 μm^1	unsigned 8	ro		
4	SAE21 μm^1	unsigned 8	ro			

Table: Communication profile (Tabellenabschnitt 5 von 7)

(a) Mapped to PDO

ENG

Idx	SIdx	Name	Type	Attr.	Standard	Notes
2003h		Condition monitoring bit field	array			
	0	Number of entries	unsigned 8	ro	08h	Largest sub-index
	1	Oil-specific bits ¹	unsigned 8	ro		0 = Conc. Limit exceeded (C >= ISO 23) 1 = Flow rate high (F > 400) 2 = Flow rate low (F < 50) 3 = Measurement values not plausible (air...), ISO (i+1) >= ISO(i) 4 = AutoMode: MessZeit reached 5 = Autoparts not reached 6 = Concentration too low
	2	reserved	unsigned 8	ro		
	3	reserved	unsigned 8	ro		
	4	reserved	unsigned 8	ro		
	5	reserved	unsigned 8	ro		
	6	reserved	unsigned 8	ro		
	7	Measurement information ¹	unsigned 8	ro		0 = measurement running 1 = measurement mode auto 2 = measurement mode I/O 3 = measurement mode manual 4 = alarm mode filter / standard
	8	Sensor alarm ¹	unsigned 8	ro		0 = laser current high (I > 2.8 mA) 1 = laser current low (I < 1 mA) 2 = Photo voltage high (U > 4V) 3 = Photo voltage low (U < 4V) 4 = Temperature high (T > 80°C) 5 = Temperature low (T < -20°C)
2004h	0	Sensor temperature ^(a)	signed 8	ro		Oil temperature in °C
2005h	0	Flow index	unsigned 16	ro		Flow index (0 ... 400)

Table: Communication profile (Tabellenabschnitt 6 von 7)

(a) Mapped to PDO

Idx	SIdx	Name	Type	Attr.	Standard	Notes
2020h		Command	unsigned 8	wo		1 = measurement start 2 = measurement stop
2030h		Measurement settings	record			
	0	Number of entries	unsigned 8	ro	2h	Largest sub-index
	1	Meas. period	unsigned 32	rw		Measurement time in s
	2	Wait time	unsigned 32	rw		Time between two measurements
2031h		Start settings	record			
	0	Number of entries	unsigned 8	ro	1h	Largest sub-index
	1	Start mode	unsigned 16	rw	0h	0 = network with NMT master (Init => PreOp => Start_Remote_Node => Operational) >0 = network without NMT master (Init => Operational)
2100h		Control functions read memory	record			
	0	Number of entries	unsigned 8	ro	3h	Largest sub-index
	1	Size of the history memory	unsigned 32	ro	Instrument-dependent	Memory size in data records
	2	History memory used	unsigned 32	ro		Occupied data records in the memory (corresponds internally to the write pointer)
	3	Read pointer, data record	unsigned 32	rw		Auto incremental read pointer to a data record to read the history memory Between 0 and the current write pointer
2101h	0	Memory reading begins segmented SDO data uploading	unsigned 16	ro		Before reading, a suitable pointer must be set (with 2100sub3), data record size is sent back after reading Thus a standardized "segmented SDO Upload" is initiated To be noted: for each data record change a toggle bit and set the appropriate bit at the end of the complete transmission

Table: *Communication profile (Tabellenabschnitt 7 von 7)*

(a) Mapped to PDO

CAN J1939

Please contact our customer service if you need information about the implementation of the CAN J1939 protocol.

Appendix

Troubleshooting

ENG

No communication on the COM port or power failures < 4 mA

Cable not connected correctly	Connect the power and communication cables correctly.
Operating voltage outside the prescribed range	Operate the sensor in the range between 9 and 36 VDC.
Communication bus incorrectly configured	Check the settings on the Communication menu.

No serial communication

Interface configuration incorrect	Check whether the interface parameters (9600, 8,1, N, N) in Patrick and PC are set correctly.
Wrong COM port	Check and correct the COM port
Incorrect spelling of the sensor commands	Check the spelling of the sensor commands, heed upper and lower-case letter.
NumLock key deactivated	Activate the NumLock key.
Shift key is on (Upper case letters)	Deactivate the upper case letters by pressing the Shift key.
Cable incorrect or defective	Use only cables from HYDROTECHNIK GmbH.

Identical measurement values in all size classes

Air in the oil	<p>Connect the particle counter to the pressure side.</p> <p>Increase the distance from the pump.</p> <p>Increase the operating pressure within the specified range.</p>
-----------------------	--

All size channels display the value 0/0/0/0

No volumetric flow	Check the supply and return lines for correct installation. Increase the operating pressure within the specified range.
There is no valid measurement result	Check the configuration and the measurement mode. Make sure that a measurement begins and is completed.
Measurement cell soiled The symbol flashes on the display ►	Clean the particle counter with clean oil or solvent such as Isopropanol. Flush with clean oil in the opposite direction.
Measurement cell defective The symbol flashes on the display ►	Contact HYDROTECHNIK GmbH.

ENG

Incorrect measurement of the analog current outputs

Incorrect parameter is output	Correct the assignment of the measurement values to the current outputs.
--------------------------------------	--

no valid application appears constantly on the display
The device keeps restarting

The basic system has a fault. All communication lines are deactivated automatically.	Contact HYDROTECHNIK GmbH.
---	----------------------------

Laser current high / photo voltage low

Air in the oil	Connect the particle counter to the pressure side. Increase the distance from the pump. Increase the operating pressure within the specified range.
Measurement cell soiled	Clean the particle counter with clean oil or solvent such as Isopropanol. Flush with clean oil in the opposite direction.

Error Code

Patrick Collects various errors, information and operating states and combines these into four 16-bit values, the ERC (error code).

Bit	ECR 1	ECR 2	ECR 3	ECR 4
0		First limit value calibration (S1) reached		Laser current too large
1		Last limit value calibration (S5) reached		Laser current too small
2				Detector voltage too small
3				Detector voltage too large
4				Temperature >80°C
5				Temperature <-20°C
6				
7				Measurement mode = Automatic
8	Concentration \geq ISO 23			Measurement running
9	Flow too high (Flow < 50)			Measurement mode = timed
10	Flow too low (Flow > 400)			Measurement mode = Digital I/O
11	ISO(i+1) \geq ISO(i)			Measurement mode = Key
12				Alarm mode: 0= Standard 1= Filter
13	Autoparts not reached			Power Up = 1 before first measurement
14	Concentration \leq ISO 9			Alarm concentration
15				Alarm temperature

Table: ERC

Errors on the display

After each measurement, **Patrick** checks various conditions. If the check produces errors during measurement or on the instrument, then these are output on the display.

The errors are output on the left of the display. The error text flashes. If more than one error is displayed, then the error texts are output so that they alternate.

Error text	Meaning	Error Code
FL LO	Flow too low	ECR 1, Bit 10
FL HI	Flow too high	ECR 1, Bit 9
CELL	Error in measurement cell	ERC 4, Bit 0, 1, 2 or 3
C LO	Concentration too low	ERC 1, Bit 14
C HI	Concentration too high	ERC 1, Bit 8
2 CLN	Measurement result not plausible	ERC 1, Bit 13

Table: *Error texts*

